

# Red Valve

**SERIES DX**  
*Slurry Knife Gate Valve*



*The Best Choice for the Toughest Applications*

## Design Features

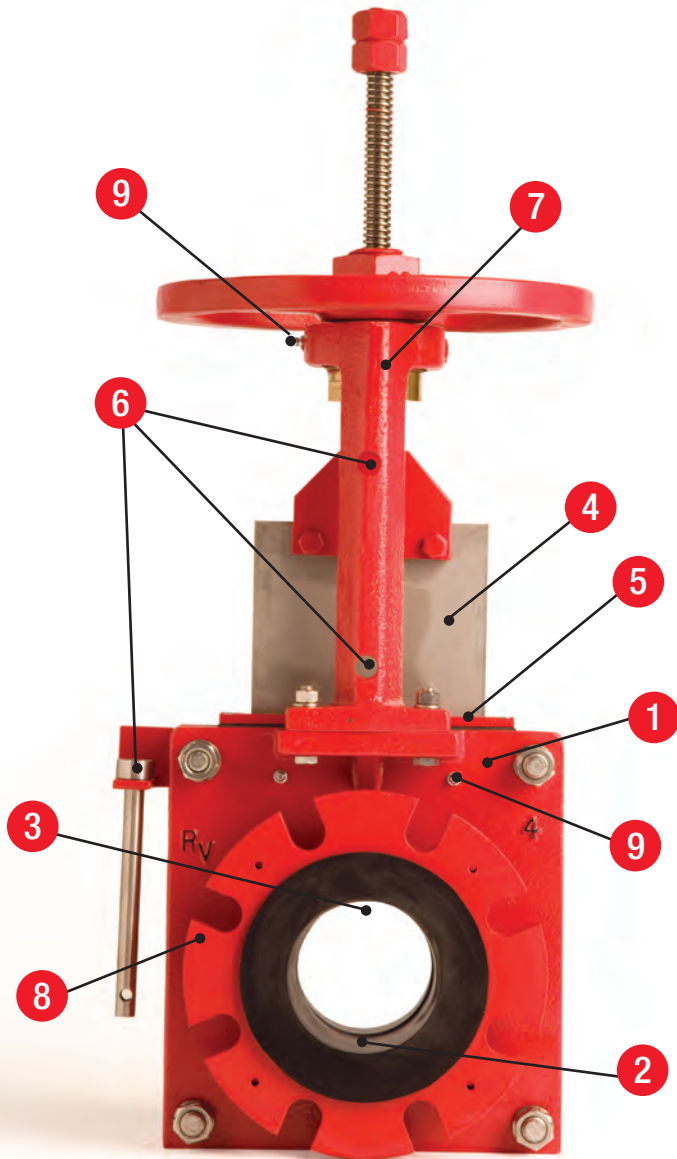

- 1 Available Sizes 3" - 36"
- 2 Abrasion-Resistant Slurry Sleeves are Field Replaceable, Provide Bi-Directional, Drop-Tight Shut-Off and Eliminate the Need for Packing
- 3 100% Full-Port Design
- 4 Heavy-Duty 316L Stainless Steel Gate
- 5 Wiper Blade Cleans Debris From Gate as It Strokes
- 6 Open/Close Lock-Out Feature (Optional)
- 7 Robust Corrosion-Resistant Ductile Iron Yoke
- 8 Slotted Flange Holes for Easy Through-Bolt Installation
- 9 Grease Fittings for Gate and Stem Lubrication

### Materials of Construction

- Ductile iron body standard 3" - 24"
- Fabricated steel body 26" - 36"
- Available sleeve materials: Pure Gum Rubber, Neoprene, Hypalon®, Chlorobutyl, BUNA-N, EPDM or Viton®
- Standard gate material: 316L S.S.
  - Optional gate materials: 17-4PH, 317L, 904L, duplex, alloy 20 and C-276
- Optional proprietary gate coatings: PTFE, PFA and FEP
- Optional splash guard and pipe-a-way containment



Special alloy gates and proprietary coatings are available to meet your unique application requirements.

# SERIES DX

## Designed for Tough Slurries

Red Valve's Series DX Slurry Knife Gate Valve is the most durable and user-friendly knife gate valve for difficult slurry applications. The fully elastomer-lined DX Valve prevents slurry build-up or dewatering by eliminating the seat cavity.

When open, the DX Valve's reinforced elastomer sleeves seal against each other and provide a 100% full-port opening which minimizes turbulence and wear. In this open position, the seats isolate and protect all metal parts of the valve from coming in contact with the process. When closed, the sleeves provide a drop-tight seal in both directions.

### Closing Action of the Series DX Slurry Knife Gate Valve

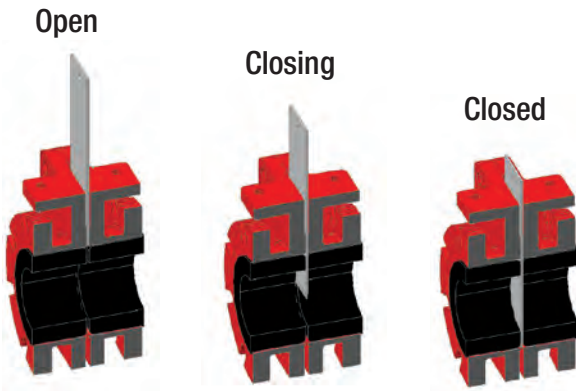

### Series DX Slurry Knife Gate Valve

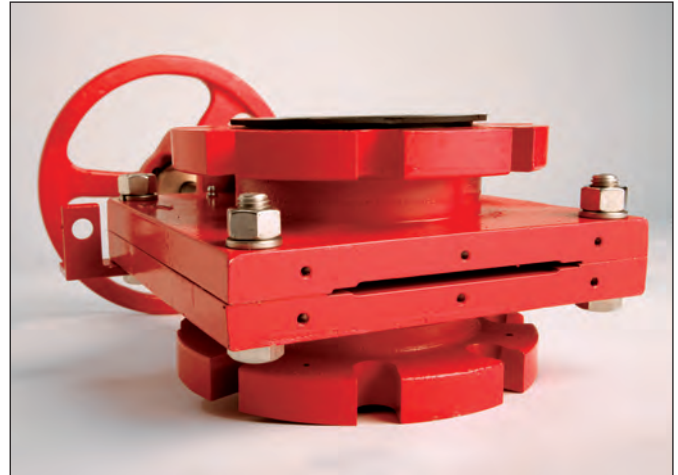
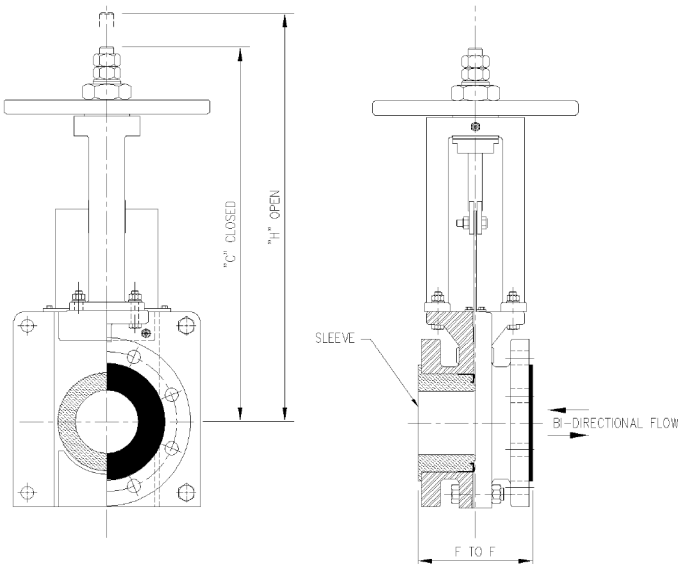

Each time the DX Valve strokes, it discharges a small amount of slurry, which keeps the gate path and seat area clear of entrapped particulates. Unlike traditional knife gate valves, the DX Valve prevents slurry build-up in the seat area, which might otherwise prohibit the valve's ability to close. Both the slurry sleeves and gate are field replaceable.

### SERIES DX SLURRY KNIFE GATE VALVE

VALVE SIZE	LENGTH F TO F		CLOSED C	OPEN H	MAXIMUM OPERATING PRESSURE IN PSI	MAXIMUM OPERATING PRESSURE IN PSI 17-4 PH GATE	WEIGHT LBS
	WITHOUT RETAINING FLANGES	WITH RETAINING FLANGES					
3"	5.875"	6.875"	17.13"	20.38"	100	150	49
4"	5.875"	6.875"	18.25"	22.63"	100	150	66
6"	6"	7"	21.06"	27.18"	100	150	109
8"	6.25"	7.25"	26.56"	34.56"	100	150	173
10"	-	8.875"	32.44"	43.63"	100	150	222
12"	-	10.125"	37"	50.88"	100	150	340
14"	-	10.125"	43.63"	57.63"	100	150	495
16"	-	11"	47.5"	63"	100	150	635
18"	-	12.125"	52.63"	70"	100	150	895
20"	-	14.125"	57.94"	74.13"	100	150	1060
24"	-	14.625"	66.68"	86.94"	100	150	2250
30"	-	15.75"	88.63"	120.63"	75	150	2388

Retaining rings are optional in valve sizes 3" - 8" and standard in sizes 10" and larger. 36" and 42" available upon request.

# Engineered Innovation

## World-Class Supplier

Red Valve has been manufacturing elastomer-based valves, such as pinch valves, knife gate valves and Tideflex® check valves, since 1953. Only the best materials from suppliers such as E.I. DuPont de Nemours, Firestone and Goodyear are used. These same materials are incorporated into the elastomer compounding and synthetic materials used in the Series DX sleeves. As a result, customers have trouble-free, high wear-resistant sleeves that outperform and outlast all other designs.

Even the toughest of slurry problems can be addressed with Red Valve's Series DX Slurry Knife Gate Valve. The sleeves are engineered to handle lime, ash, gypsum, chemicals, and mining slurry, such as tailings, cyclone feed and thickener underflow.



## Superior Sleeve Design



The most critical part of the DX Valve is the design, construction and selection of the sleeve. Drawing from over 55 years of experience, Red Valve's sleeves are superior in design, construction and performance, and incorporate advanced elastomer technology.

Extensive in-house testing and proprietary formulation of elastomers allow Red Valve to guarantee the sleeves against fatigue or loss of compression for 50,000 cycles!

Each DX sleeve is manufactured with an internal stiffening ring to maintain the integrity and shape of the sleeve. Red Valve DX sleeves are interchangeable with other style Slurry Knife Gate Valves.

## Low Maintenance Design

The Series DX Slurry Knife Gate Valve is designed specifically for low-maintenance. There are no seats, packing, seals or bellows to routinely replace; instead, the sleeves are the only replacement part required. Once these have been replaced, the valve is like new again.



Red Valve inventories hundreds of DX sleeves in a variety of material combinations.

## Materials of Construction

### ELASTOMER:

- Pure Gum Rubber
- Neoprene
- Chlorobutyl
- BUNA-N
- Hypalon
- EPDM
- Viton

### TEMPERATURE:

- 50°F to 180°F
- 50°F to 220°F
- 60°F to 300°F
- 40°F to 240°F
- 60°F to 275°F
- 60°F to 300°F
- 10°F to 400°F

### RESISTANT TO:

- Mild chemicals, organic acids, alcohols, salts
- Moderate acids, chemicals, ozone, oils, fats
- Animal and vegetable oils, fats, greases
- Most hydrocarbons, fats, oils, greases, hydraulic fluids, chemicals, solvents
- Strong acids, bases, freons, hydroxides, ozone, alcohols, etching, alkaline and hypochlorite solutions
- Animal and vegetable oils, fats, ozone
- Hydrocarbons, many acids, animal and vegetable oils

# SERIES DX

*Designed for Tough Slurries*

## ENHANCED DESIGN FEATURES:

### Double Pinned Gate/Clevis Assembly



The Series DX incorporates a double pin clevis-to-gate assembly designed to overcome excessive torque, tension and compression forces typically found in heavy slurry applications. This design distributes forces from clevis to gate preventing gate pull-through when opening and binding while closing.

### Lock-Out Feature

An optional lock-out safety feature is available. Once placed into position, the lock-out pin will keep the valve stem in a fixed position, deterring unauthorized operation of the valve. This pin is permanently attached to the valve by a flexible wire cable.



### Splash Containment

The new DX Valve has an optional clean-out area at the base of the body for splash containment. At the bottom of the valve is a removable drain plate. The clean-out area should be considered as a way to eliminate the need for an external splash guard, or can be utilized as a flush or purge connection.

### Wiper Blade



A wiper blade mounted on the top of the valve prevents the gate lubricant and process from leaking through the top. The DX Valve design eliminates the need for traditional packing. This wiper blade also prevents external grit from entering the valve body.

### Retaining Flanges

UHMW retaining flanges provide for an easier installation, provide sleeve compression, and make the valve useable for dead-end service.



Retaining flanges are standard in valve sizes 10" and larger and optional in valve sizes 3" - 8".

### Gate and Stem Lubrication

By lubricating the gate each time it cycles through the sleeves, the DX Valve provides smoother gate movement and longer sleeve life. It also requires less force to operate the valve. By packing the valve chest with a heavy-duty lubricant, Red Valve minimizes environmental grit from entering the valve body.



# Actuation Options

## Hydraulic

Series DX Slurry Knife Gate Valves are available with hydraulic actuators. Standard and high-pressure-rated hydraulic actuators can be provided.



A portable hydraulic power unit can be specified to actuate the DX Valve. A transportable unit is especially convenient for actuating valves in out-of-reach or inconvenient locations, such as tailing lines. Also common is the use of one portable hydraulic unit to actuate multiple valves in close proximity, as found at a cyclone separator.

A portable hydraulic power unit can also be used for remote locations. Manually or electrically powered models are available.



## Motor-Operated

The motor-operated Series DX Slurry Knife Gate Valve is reliable and provides reduced maintenance. Motor operators are cost-effective and ideal for remote operations.



A motor-operated DX Valve can be provided with a variety of electric actuators. Heaters, thermostats, position indicators, reversing starters and indicator lights are included as standard. Also included in our standard motor package are declutch and override components.

Controls can be furnished as an integral part of the electric operator or as a separate unit for a remote station. Optional features include NEMA 7 explosion-proof construction, proportioning control from a 4-20mA instrument signal and 4-20mA output transfer.

AUMA<sup>®</sup>, Limitorque<sup>®</sup> or Rotork<sup>®</sup> electric operators are standard. Other electric motor operators are available upon specific request.

## Bevel Gears



Bevel gears are recommended for high-pressure service or larger diameter valves. Suggested on all DX Valves over 6" in diameter and above 75 psi working pressure.

Standard WBG-16 1600 ft.-lb. 4:1 gear ratio with handwheel axis parallel to pipe access.

### Optional Stem Covers

In particularly tough environments, an optional steel or Lexan<sup>®</sup> stem cover can be used to protect the stem threads. An accordion-style, flexible elastomer boot is also available to shield the lower stem threads.

# SERIES DX

Designed for Tough Slurries

## Pneumatic Cylinder

Red Valve's Series DX Slurry Knife Gate Valves are also available with pneumatic cylinder actuators. Options include (but are not limited to) limit switches, solenoids and air regulators.



Red Valve manufactures its pneumatic cylinder actuators with a fiberglass-reinforced epoxy resin. The cylinder material is inert to most corrosive chemicals, hydraulic fluids, water and oil. It has an operating temperature range from -90° F to 225° F and can withstand maximum working pressures of 250 psi. Inside actuator walls are polished and impregnated with molydisulfide for reduced friction and wear.

The piston rod is made of polished 304 stainless steel and sealed with a polyurethane lip seal. Both the piston rod and seal are

protected by a wiper ring that cleans the piston rod before it passes through the lip seal. The rod seal and wiper ring are held in place by a bronze stem bushing, which prevents galling of the piston rod. The combination of a stainless steel piston rod, wiper ring and lip seal contributes to extend actuator life.

## Double-Acting Actuator

Air-to-Open/Air-to-Close (ATO/ATC) "R" style actuators are used on the Series DX Valve.

## Single-Acting Actuator

Air-to-Open/Fail Close Spring (ATO/FCS) and Air-to-Close/Fail Open Spring (ATC/FOS) series "RS" style actuators consist of either a fail-close spring, which is preloaded to provide sufficient force to close the gate upon air loss, or a fail-open spring, which drives the valve open upon air loss. Contact factory for size range of spring return actuators.

Standard tubing is polyethylene. Optional tubing includes copper, PVC-coated copper and stainless steel.

## Pneumatic Actuator Materials of Construction

- Composite cylinder tube
- Neoprene o-ring seal
- 304 stainless steel piston rod
- Polypak or BUNA-N wiper ring
- SAE grade 5 carbon steel threaded tie rods
- Stainless steel fastening
- T6061 aluminum cylinder

## Non-Rising

Red Valve's Non-Rising Stem Series DX Slurry Knife Gate Valve is built to the same engineering standards as the traditional DX Valve. The Non-Rising Stem feature allows this valve to be used where overhead space is limited. Removable rubber sleeves on either side of the gate provide a bi-directional seal and excellent wear resistance. The seats are reinforced and available in a wide variety of elastomers for abrasion resistance and chemical compatibility.



The DX Valve with non-rising stem is available in sizes 3" - 24" and is provided with standard handwheel mechanisms featuring fabricated aluminum tubular handwheels. Gear operators as well as pneumatic and electric operators are also available.

## The Best Choice for the Toughest Applications.

In addition to the Series DX Slurry Knife Gate Valve, Red Valve has a complete package of other slurry valves.

### MANUAL PINCH VALVES

Red Valve Manual Pinch Valves have excellent abrasion-resistant characteristics and have the same face-to-face as gate, plug and ball valves in sizes through 12". The valve's elastomer sleeve is the only wetted part. When open, the sleeve is full-port, which minimizes turbulence and wear. When closed, the valve provides 100% drop-tight shut-off, bi-directionally. Manual pinch valves have become the standard in the mining industry for tailing lines and spigot applications.



This information presented in this catalog is provided in good faith. Red Valve Company, Inc. reserves the right to modify or improve its design specifications without notice, and does not imply any guarantee or warranty for any of its products from reliance upon the information contained herein. All orders are subject to Red Valve's standard terms and warranty and are subject to final acceptance by Red Valve.

Viton is a registered trademark of DuPont Dow Elastomers. Teflon is a registered trademark of the DuPont Company. Hypalon is a registered trademark of DuPont Performance Elastomers. Lexan is a registered trademark of SABIC Innovative Plastics. AUMA is a registered trademark of AUMA Actuators, Inc. Rotork is a registered trademark of Rotork Controls Limited. Limitorque is a registered trademark of Flowserve Corporation. Tideflex, Red Valve, and the Red Valve "rv" logo are registered trademarks of the Red Valve Company, Inc.

© 2008 Red Valve Company.  
All rights reserved.

### PINCH VALVES FOR THROTTLING SERVICE

Red Valve Control Pinch Valves offer maximum durability with precise control, which virtually eliminates maintenance. A heavy-duty pinch mechanism positions the sleeve for accurate and repeatable control over a wide flow range. Red Valve's patented cone sleeve trim should be specified to further enhance control performance.



RVSDX 10/09

### LARGE DIAMETER AND HIGH PRESSURE PINCH VALVES

Red Valve high-pressure pinch valves are ideal in mine tailing service. Pinch valves are available in ANSI 150 and 300lb Class and can be optioned with gear operators, electric motors or hydraulic actuation.



600 N. Bell Avenue

Carnegie, PA 15106

p: 412.279.0044

f: 412.279.7878

valves@redvalve.com

www.redvalve.com

For additional related products, please see our Power and Mining Valve Selection Guides.

